

Features

- Ceramic Core
- High frequency design
- Excellent Q values
- High reliability
- Excellent thermal stability

Applications

- Modems
- Mobile Radios
- Cordless Telephones
- Global Positioning Systems
- Telecommunications Systems

► Dimensions & Configurations (Unit:mm)

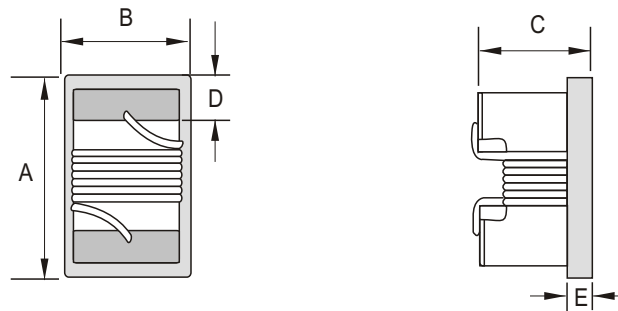

Type	A	B	C	D	E
MSCC1005(0402)	1.00±0.1	0.55±0.1	0.50±0.1	0.20±0.1	0.5
MSCC1608(0603)	1.60±0.2	1.05±0.2	1.05±0.2	0.35±0.1	0.5
MSCC2012(0805)	2.00±0.2	1.25±0.2	1.20±0.2	0.40±0.1	0.5
MSCC2520(1008)	2.50±0.2	2.00±0.2	1.60±0.2	0.50±0.1	0.5
MSCC3225(1210)	3.20±0.2	2.50±0.2	2.20±0.2	0.50±0.1	0.5

▶ Electrical Characteristics For MSCC1005 Series

Part Number	Inductance [nH]	Tolerance	Q		SRF (Min) [MHz]	DCR (max) [Ω]	IDC (Max) [mA]
			Min	Typical			
MSCC1005-1N0	1.0@ 250MHz	±10%	13	26@ 900MHz	6000	0.045	1360
MSCC1005-2N0	2.0@ 250MHz	±10%	16	30@ 900MHz	6000	0.070	1040
MSCC1005-2N2	2.2@ 250MHz	±10%	18	32@ 900MHz	6000	0.070	960
MSCC1005-3N3	3.3@ 250MHz	±10%	20	41@ 900MHz	6000	0.066	840
MSCC1005-3N6	3.6@ 250MHz	±10%	20	43@ 900MHz	6000	0.066	840
MSCC1005-3N9	3.9@250MHz	±10%	20	41@ 900MHz	5800	0.066	840
MSCC1005-5N1	5.1@ 250MHz	±10%	23	49@ 900MHz	5800	0.083	800
MSCC1005-5N6	5.6@ 250MHz	±10%	23	46@ 900MHz	5800	0.083	760
MSCC1005-6N2	6.2@ 250MHz	±10%	23	49@ 900MHz	5800	0.083	760
MSCC1005-7N5	7.5@ 250MHz	±10%	25	50@ 900MHz	5800	0.104	680
MSCC1005-8N2	8.2@ 250MHz	±10%	25	49@ 900MHz	4400	0.104	680
MSCC1005-9N0	9.0@ 250MHz	±10%	25	49@ 900MHz	4160	0.104	680
MSCC1005-10N	10@ 250MHz	±10%	23	47@ 900MHz	3900	0.195	480
MSCC1005-11N	11@ 250MHz	±10%	26	56@ 900MHz	3680	0.120	640
MSCC1005-12N	12@ 250MHz	±5%	26	51@ 900MHz	3600	0.120	640
MSCC1005-15N	15@ 250MHz	±5%	26	54@ 900MHz	3280	0.172	560
MSCC1005-19N	19@ 250MHz	±5%	26	50@ 900MHz	3040	0.202	480
MSCC1005-23N	23@ 250MHz	±5%	26	53@ 900MHz	2720	0.214	400
MSCC1005-27N	27@ 250MHz	±5%	26	48@ 900MHz	2480	0.298	400
MSCC1005-36N	36@ 250MHz	±5%	26	48@ 900MHz	2320	0.403	320
MSCC1005-40N	40@ 250MHz	±5%	26	48@ 900MHz	2240	0.438	320
MSCC1005-47N	47@200MHz	±5%	26	46@ 900MHz	2100	0.830	150

► Electrical Characteristics For MSCC1608 Series

Part Number	Inductance [nH]	Tolerance	Q		SRF (Min) [MHz]	DCR (max) [Ω]	IDC (Max) [mA]
			Min	Typical			
MSCC1608-2N2	2.2 @ 250MHz	±5%	16	31 @ 900MHz	6900	0.08	700
MSCC1608-3N9	3.9 @ 250MHz	±5%	22	51 @ 900MHz	6900	0.08	700
MSCC1608-4N7	4.7 @ 250MHz	±5%	20	47 @ 900MHz	5800	0.11	700
MSCC1608-6N8	6.8 @ 250MHz	±10%	30	63 @ 900MHz	5800	0.11	700
MSCC1608-8N2	8.2 @ 250MHz	±10%	30	72 @ 900MHz	4600	0.10	700
MSCC1608-10N	10 @ 250MHz	±10%	30	66 @ 900MHz	4800	0.13	700
MSCC1608-12N	12 @ 250MHz	±10%	35	72 @ 900MHz	4000	0.13	700
MSCC1608-15N	15 @ 250MHz	±10%	35	68 @ 900MHz	4000	0.17	700
MSCC1608-18N	18 @ 250MHz	±10%	38	77 @ 900MHz	3100	0.17	700
MSCC1608-22N	22 @ 250MHz	±10%	38	70 @ 900MHz	3000	0.22	700
MSCC1608-27N	27 @ 250MHz	±10%	40	75 @ 900MHz	2800	0.22	600
MSCC1608-33N	33 @ 250MHz	±10%	43	78 @ 900MHz	2300	0.22	600
MSCC1608-39N	39 @ 250MHz	±10%	43	66 @ 900MHz	2200	0.25	600
MSCC1608-47N	47 @ 200MHz	±10%	40	65 @ 900MHz	2000	0.28	600
MSCC1608-56N	56 @ 200MHz	±10%	40	66 @ 900MHz	1900	0.31	600
MSCC1608-68N	68 @ 200MHz	±10%	40	57 @ 900MHz	1700	0.34	600
MSCC1608-72N	72 @ 150MHz	±10%	35	60 @ 900MHz	1700	0.49	400
MSCC1608-82N	82 @ 150MHz	±10%	35	58 @ 900MHz	1700	0.54	400
MSCC1608-R10	100 @ 150MHz	±10%	35	51 @ 900MHz	1400	0.63	400
MSCC1608-R12	120 @ 150MHz	±10%	35	45 @ 900MHz	1300	0.65	300
MSCC1608-R15	150 @ 150MHz	±10%	35	33 @ 900MHz	1000	0.92	280
MSCC1608-R18	180 @ 100MHz	±10%	30	26 @ 900MHz	1000	1.25	240
MSCC1608-R22	220 @ 100MHz	±10%	30	23 @ 900MHz	1000	1.70	200
MSCC1608-R27	270 @ 100MHz	±10%	30	10 @ 900MHz	1000	1.80	170

▶ Electrical Characteristics For MSCC2012 Series

Part Number	Inductance [nH]	Tolerance	Q (Min)	SRF (Min) [MHz]	DCR (max) [Ω]	IDC (Max) [mA]
MSCC2012-2N2	2.2 @ 250MHz	±5%	50 @1000MHz	6000	0.06	800
MSCC2012-2N7	2.7 @ 250MHz	±5%	35 @1000MHz	6000	0.08	800
MSCC2012-3N3	3.3 @250MHz	±5%	60 @1000MHz	6000	0.08	800
MSCC2012-3N9	3.9 @ 250MHz	±5%	60 @1000MHz	6000	0.06	600
MSCC2012-4N7	4.7 @ 250MHz	±5%	60 @1000MHz	5800	0.06	600
MSCC2012-5N6	5.6 @ 250MHz	±10%	60 @1000MHz	5800	0.08	600
MSCC2012-6N8	6.8 @ 250MHz	±10%	60 @1000MHz	5500	0.06	600
MSCC2012-8N2	8.2 @ 250MHz	±10%	60 @1000MHz	5500	0.06	600
MSCC2012-10N	10 @ 250MHz	±10%	60 @ 500MHz	4800	0.08	600
MSCC2012-12N	12 @ 250MHz	±10%	60 @ 500MHz	4100	0.08	600
MSCC2012-15N	15 @ 250MHz	±10%	60 @ 500MHz	3600	0.08	600
MSCC2012-18N	18 @ 250MHz	±10%	60 @ 500MHz	3400	0.08	600
MSCC2012-22N	22 @ 250MHz	±10%	60 @ 500MHz	3300	0.10	600
MSCC2012-27N	27 @ 250MHz	±10%	60 @ 500MHz	2600	0.12	600
MSCC2012-33N	33 @ 250MHz	±10%	60 @ 500MHz	2400	0.15	500
MSCC2012-39N	39 @ 250MHz	±10%	60 @ 500MHz	2100	0.18	500
MSCC2012-47N	47 @ 200MHz	±10%	60 @ 500MHz	1700	0.15	500
MSCC2012-56N	56 @ 200MHz	±10%	60 @ 500MHz	1600	0.25	500
MSCC2012-68N	68 @ 200MHz	±10%	60 @ 500MHz	1450	0.27	500
MSCC2012-82N	82 @ 150MHz	±10%	60 @ 500MHz	1350	0.32	500
MSCC2012-R10	100 @ 150MHz	±10%	60 @ 500MHz	1200	0.43	500
MSCC2012-R12	120 @ 150MHz	±10%	50 @ 250MHz	1100	0.48	500
MSCC2012-R15	150 @ 100MHz	±10%	50 @ 250MHz	950	0.56	400

▶ Electrical Characteristics For MSCC2520 Series

Part Number	Inductance [nH]	Tolerance	Q (Min)	SRF (Min) [MHz]	DCR (max) [Ω]	IDC (Max) [mA]
MSCC2520-3N3	3.3 @ 100MHz	±5%	50 @1000MHz	6000	0.06	1000
MSCC2520-6N8	6.8 @ 100MHz	±10%	50 @1000MHz	5500	0.06	1000
MSCC2520-8N2	8.2 @ 100MHz	±10%	50 @1000MHz	5500	0.06	1000
MSCC2520-10N	10 @ 100MHz	±10%	50 @1000MHz	4300	0.08	1000
MSCC2520-12N	12 @ 100MHz	±10%	60 @ 500MHz	3600	0.08	1000
MSCC2520-15N	15 @ 100MHz	±10%	60 @ 500MHz	2700	0.08	1000
MSCC2520-18N	18 @ 100MHz	±10%	60 @ 350MHz	2700	0.10	1000
MSCC2520-22N	22 @ 100MHz	±10%	60 @ 350MHz	2500	0.10	1000
MSCC2520-27N	27 @ 100MHz	±10%	60 @ 350MHz	1800	0.10	1000
MSCC2520-33N	33 @ 100MHz	±10%	60 @ 350MHz	1700	0.10	1000
MSCC2520-39N	39 @ 100MHz	±10%	60 @ 350MHz	1500	0.10	1000
MSCC2520-47N	47 @ 100MHz	±10%	60 @ 350MHz	1500	0.10	1000
MSCC2520-56N	56 @ 100MHz	±10%	60 @ 350MHz	1350	0.12	1000
MSCC2520-68N	68 @ 100MHz	±10%	60 @ 350MHz	1300	0.15	1000
MSCC2520-82N	82 @ 100MHz	±10%	60 @ 350MHz	1100	0.18	1000
MSCC2520-R10	100 @ 100MHz	±10%	60 @ 350MHz	1100	0.18	1000
MSCC2520-R12	120 @ 25MHz	±10%	45 @ 100MHz	950	0.20	800
MSCC2520-R15	150 @ 25MHz	±10%	45 @ 100MHz	880	0.22	800
MSCC2520-R18	180 @ 25MHz	±10%	45 @ 100MHz	800	0.33	800
MSCC2520-R22	220 @ 25MHz	±10%	45 @ 100MHz	730	0.45	800
MSCC2520-R27	270 @ 25MHz	±10%	45 @ 100MHz	650	0.75	600
MSCC2520-R33	330 @ 25MHz	±10%	45 @ 100MHz	570	0.90	500
MSCC2520-R39	390 @ 25MHz	±10%	45 @ 100MHz	530	1.06	470
MSCC2520-R47	470 @ 25MHz	±10%	45 @ 100MHz	480	1.17	420
MSCC2520-R56	560 @ 25MHz	±10%	45 @ 100MHz	430	1.50	310
MSCC2520-R68	680 @ 25MHz	±10%	45 @ 100MHz	380	2.06	230
MSCC2520-R75	750 @ 25MHz	±10%	45 @ 100MHz	360	2.20	200
MSCC2520-R82	820 @ 25MHz	±10%	45 @ 100MHz	350	2.30	180
MSCC2520-R91	910 @ 25MHz	±10%	45 @ 100MHz	330	3.18	150
MSCC2520-1R0	1000 @ 25MHz	±10%	35 @ 50MHz	310	3.30	120

► Electrical Characteristics For MSCC3225 Series

Part Number	Inductance [nH]	Tolerance	Q (Min)	SRF (Min) [MHz]	DCR (max) [Ω]	IDC (Max) [mA]
MSCC3225-4N7	4.7 @ 100MHz	±5%	50 @ 1000MHz	6000	0.06	1000
MSCC3225-5N6	5.6 @ 100MHz	±10%	50 @ 1000MHz	5500	0.08	1000
MSCC3225-10N	10 @ 100MHz	±10%	60 @ 500MHz	4000	0.06	1000
MSCC3225-12N	12 @ 100MHz	±10%	60 @ 500MHz	3400	0.06	1000
MSCC3225-15N	15 @ 100MHz	±10%	60 @ 500MHz	3200	0.06	1000
MSCC3225-18N	18 @ 100MHz	±10%	60 @ 300MHz	2800	0.06	1000
MSCC3225-22N	22 @ 100MHz	±10%	60 @ 300MHz	2300	0.08	1000
MSCC3225-27N	27 @ 100MHz	±10%	60 @ 300MHz	2000	0.08	1000
MSCC3225-33N	33 @ 100MHz	±10%	60 @ 300MHz	1800	0.08	1000
MSCC3225-39N	39 @ 100MHz	±10%	60 @ 300MHz	1800	0.08	1000
MSCC3225-47N	47 @ 100MHz	±10%	60 @ 300MHz	1600	0.08	1000
MSCC3225-56N	56 @ 100MHz	±10%	60 @ 300MHz	1500	0.10	1000
MSCC3225-68N	68 @ 100MHz	±10%	60 @ 300MHz	1300	0.10	1000
MSCC3225-82N	82 @ 100MHz	±10%	60 @ 300MHz	1200	0.10	1000
MSCC3225-R10	100 @ 100MHz	±10%	60 @ 300MHz	1100	0.10	1000
MSCC3225-R12	120 @ 50MHz	±10%	60 @ 300MHz	900	0.12	800
MSCC3225-R15	150 @ 50MHz	±10%	60 @ 300MHz	800	0.18	800
MSCC3225-R18	180 @ 50MHz	±10%	60 @ 300MHz	760	0.21	800
MSCC3225-R22	220 @ 50MHz	±10%	60 @ 300MHz	760	0.27	800
MSCC3225-R27	270 @ 50MHz	±10%	50 @ 300MHz	660	0.33	700
MSCC3225-R33	330 @ 50MHz	±10%	50 @ 100MHz	550	0.37	650
MSCC3225-R39	390 @ 50MHz	±10%	50 @ 100MHz	500	0.63	600
MSCC3225-R47	470 @ 50MHz	±10%	50 @ 100MHz	450	0.69	550
MSCC3225-R56	560 @ 50MHz	±10%	50 @ 100MHz	400	0.90	450
MSCC3225-R68	680 @ 25MHz	±10%	50 @ 100MHz	380	1.05	400
MSCC3225-R82	820 @ 25MHz	±10%	50 @ 100MHz	350	1.45	350
MSCC3225-1R0	1000 @ 25MHz	±10%	45 @ 100MHz	300	1.90	280
MSCC3225-1R2	1200 @ 7.96MHz	±10%	45 @ 50MHz	300	2.20	250
MSCC3225-1R5	1500 @ 7.96MHz	±10%	45 @ 50MHz	250	2.43	220
MSCC3225-1R8	1800 @ 7.96MHz	±10%	45 @ 50MHz	200	3.36	180
MSCC3225-2R2	2200 @ 7.96MHz	±10%	40 @ 50MHz	200	3.50	150